



- Back Road Equipment
Slider Rear Rack Installation
Instructions 2008 & newer
KLR650

Tools Required:

8mm socket

4 mm hex wrench (Allen wrench)

5 mm hex wrench (Allen wrench)

3/16" allen socket

1/4" drill bit

21/64" drill bit

1/4" drive In. lbs. torque wrench

electric hand drill

tape measure or ruler

marking pen

242 Blue Loctite thread locker or
similar

- Kit Contents:

- 1 Slider Plate with cam lever

- 4 pucks

- 4 - 5/16" Button Head Screws

- 4 - 1.5" diameter aluminum washer

- 4 - 6 mm flat head screws

- 4 round aluminum spacers

Do not exceed the OEMs
recommendation for weight on the
rear rack of the motorcycle!!



Step 1 Remove the 4 tail cover screws.

These screws will not be used to install the rack. Save these screw in case you ever want to reinstall the OEM rack.

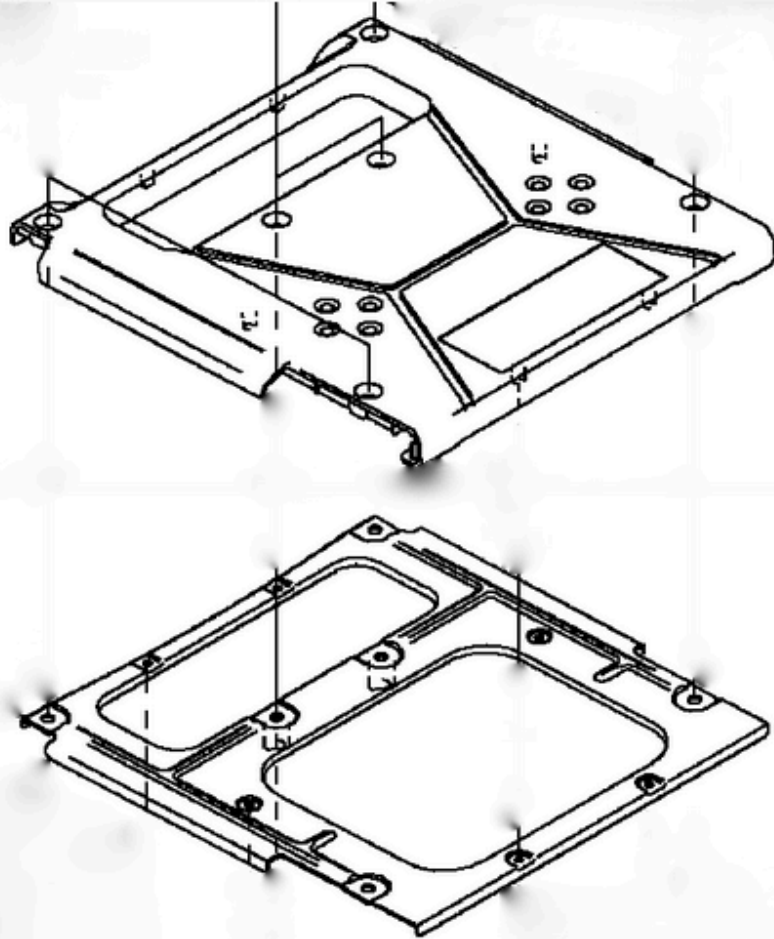

Step 2 Look at the underneath of the plastic OEM rack. There is a stamped steel plate screwed to the plastic rack. Remove the stamped steel part, **THIS MUST BE INSTALLED BACK ON THE MOTORCYCLE!**



Step 3 Re-install the 2 socket head 6 mm screws with the original washers, apply 242 blue Loctite. Torque the screws to 105 inch pounds.

Note: The stamped steel plate shown in the photo must be installed on the bike as shown.



Step 4 Install the aluminum spacers where the 6mm threaded holes are located.



IMPORTANT!!!!

If you are installing a top box and quick connect kit skip step 5 and go to step 6.

Step 5 Apply Blue 242 Loctite to the 4 flat head screws and attach the the rack with the screws. Torque the fasteners to 100 inch pounds. This completes the rack installation. Step 6 is for top box quick connect installation.



Step 6 Attach the rack to the motorcycle with the 4 flat head screws as shown. Just snug the screws for now as you will be removing them in a later step.



Step 7 Install the master puck.

Install one of the pucks in the lever key hole (circled).

Install the other 3 pucks in the keyholes and seat them in the rear of the keyhole.



Step 8 Place the top box on top of the pucks and position it where you would like it located.

The box should be located as far forward as possible without interfering with seat removal and passenger space.



Step 9 Mark the location of the master puck onto the top box with a marker.

Fore and aft position of the top box is the priority here, the side to side placement will be adjusted later.



Step 10 Place the box on a table or other work surface. Remove the 4 flat head screws holding the rack onto the motorcycle.

Place the rack on top of the box.



Step 11 Locate the puck marker on the box and align the master puck up with the mark as it was on the bike.

Adjust the box side to side and make any final adjustments to the location.



Step 12 Make certain the plate is positioned on the box where you would like it. A helping hand would be useful during the next few steps but it can be done solo.

With a $\frac{1}{4}$ " drill bit and electric drill use the master puck as a drill guide and drill a pilot hole through the box.



Step 13 Remove the rack from the box. Use the $\frac{21}{64}$ " drill bit and electric drill to enlarge the $\frac{1}{4}$ " pilot hole.



Step 14 Use a 8mm button head cap screw and 38mm OD aluminum washer to attach the master puck to the box.



Step 15 Place the rack with the other 3 pucks onto the master puck and latch it into position. Square up the plate and box to each other (last chance).



Step 16 With the $\frac{1}{4}$ " drill bit, use the puck diagonally across from the master puck as a drill guide and drill a second pilot hole in the box.

Make sure the pucks are seated in the keyholes before drilling!!



Step 17 Remove the rack and pucks from the box. Use the $\frac{21}{64}$ " drill bit and electric drill to enlarge the second $\frac{1}{4}$ " pilot hole.



Step 18 Bolt the second puck to the box. Place the rack on the box and latch it into position. With the $\frac{1}{4}$ " drill bit use the 2 remaining pucks as drill guides and drill the last 2 pilot holes.

Make sure the pucks are seated in the keyholes before drilling!!



Step 19 Remove the rack and pucks from the box. Use the $21/64$ " drill bit and electric drill to enlarge the last $2\ 1/4$ " pilot holes.



Step 20 Install all pucks onto the box using the 38mm aluminum washers and 8mm button head cap screws. Do not fully tighten at this time.



Step 21 Apply Blue 242 Loctite to the 4 flat head screws and attach the the rack with the screws. Torque the fasteners to 100 inch pounds. This completes the rack installation.



Step 22 Install the box onto rack and latch it into place with the cam lever.



Step 23 Torque the puck screws to 108 in. lbs.



That completes the installation process. Test ride the motorcycle and then check all the fasteners for tightness. Also check the fasteners again after 1000 miles and at every oil change after that.

For security a 3/16" pad lock can be used to lock the cam lever in the closed position.

Thank You

